



**ALUMINIUM
FORMWORK
FOR A BETTER
WORLD**

GRS[®]
ALUMINIUM FORMWORK



Company Profile

Over the past years, GRS, the three times winner of export excellency awards from the Govt. of India, has established in self as the leading organization in the field of the high quality formwork and scaffolding system for the construction and maintenance industry in India and also as a major exporter. Through a network of join-venture companies and subsidiaries, it is now spread a lot of part of the world. GRS's reputation has been built up steadily over the years by putting the needs its customers ABOVE EVERY OTHER CONSIDERATION.

Everything we do is design to help our customers achieve maximum on site efficiency without compromising safety standards. The success of any construction project depends on how closely you stick to planned time schedules and cost estimates. When you purchase formwork and scaffolding equipment from GRS, you are able to draw the resources of a well spread service organization. Regardless of the specific type of equipment and site location, we will work with you to ensure your project to run according to plan. The extensive design and manufacturing resources of GRS give us the ability to develop or adopt products quickly to suit the constantly changing needs of our customers.



Aluminium Formwork Systems

Aluminium formwork system is highly suited to load bearing wall construction whereas traditional formwork consisting of plywood and Timber is not suitable to the high pressure of fresh concrete on the wall. Use of this formwork in load bearing design gives an average of 15% cost saving in the structure of the building and increased usable floor space of 8% over RCC design of the assembly. Only unskilled labours are required with minimal supervision. The aluminium formwork system is removable and can be reused hundreds of times with little maintenance. Moreover, the requirement of steel is also reduced in this technology as aluminium has a higher scrap value.

This system is based on a handled light aluminium formwork system. It is capable of forming the concrete for both, load bearing wall design and column beam design. Unlike other systems it is equally suited to both high rise and low rise buildings. In case of load bearing wall design, the systems form all of the concrete in a building, including walls, floor slabs, columns, beams, stairs, window hoods and balconies. Specifically designed to allow the rapid construction of multiple unit projects at optimum productivity, the aluminium formwork can be used for a broad range of applications from straight forward panel to more complicated structures involving bay windows, stairs and A/C hoods. The degree of Pre engineering and inherent simplicity of the aluminium formwork enables unskilled labour to be used. Every component is light enough to be handled by one operative, minimising the need for a heavy lifting equipment.

The simplicity of aluminium formwork and the repetitive nature of the assembly process make it possible to accurately programme construction sequences and thus cycle times well in advance. In addition, this enables the unskilled labour to work with the formwork, therefore reducing the burden on skilled labour when this is in short supply. On leaving the factory, all panels are clearly labelled to ensure that they are easily identifiable on site and can be smoothly fitted together using the formwork modulation drawings.

Special Features

Characteristics

	Formwork Type				
	Hard Held Formwork	Tunnel Formwork	Table Formwork	Traditional Formwork	GRS Aluminium Formwork
Can pour all walls, columns and beams together with floor slabs, permitting cellular design, and savings in Steel and concrete.					✓
Lowest formwork to forming area ratio					✓
No skilled labour required	✓				✓
Strike floor slabs formwork without movint props					✓
Able to pour walls (column) and floor slabs with beams with one lift		✓			✓
Can form concrete in place as part of work cycle					✓
Can form concrete columns and beams together	✓			✓	✓
No cranes or other heavy equipment required	✓				✓
Suitable for single (1) or two(2) storey building		✓	✓	✓	✓
Suitable for high-rise buildings				✓	✓
Formworks equipment adapts to different designs					✓
Able to form all concrete elements				✓	✓
Confirms to architect design with no need modifications two suit the system	✓			✓	✓
Self correction feature providing unmatched forming accuracy					✓
Environmentally friendly no huge debris, no Messi disposals	✓				✓

Specification

	Aluminium(a6061-t6)		
	List	Unit	Combined Aluminium (a6061-t6)
Material	Specific gravity	-	2.7
	Allowable bending stress	kg/cm ²	7.0 x 10 ²
	Young's modulus	kg/cm ²	kg/cm ²
Composition	Inner wall panel		Slab corner & beam
	Slab panel & support		In-Out corner & hunch
	Accessory		Wall tie / round pin/wedge pin
Normal module	Wall panel		2050MMx600
	Slab Panel		1200MMx600

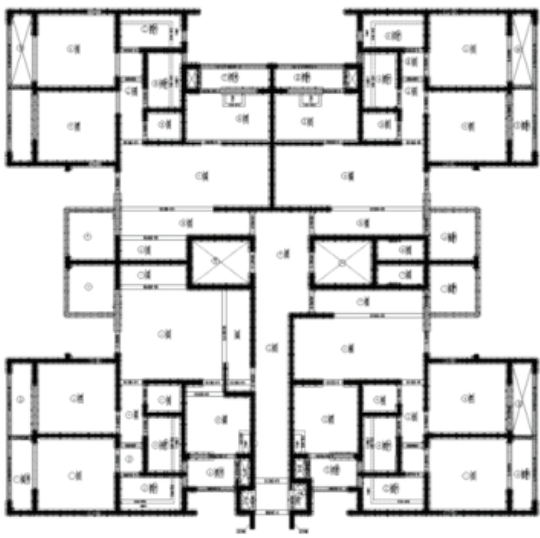

Shell Plan

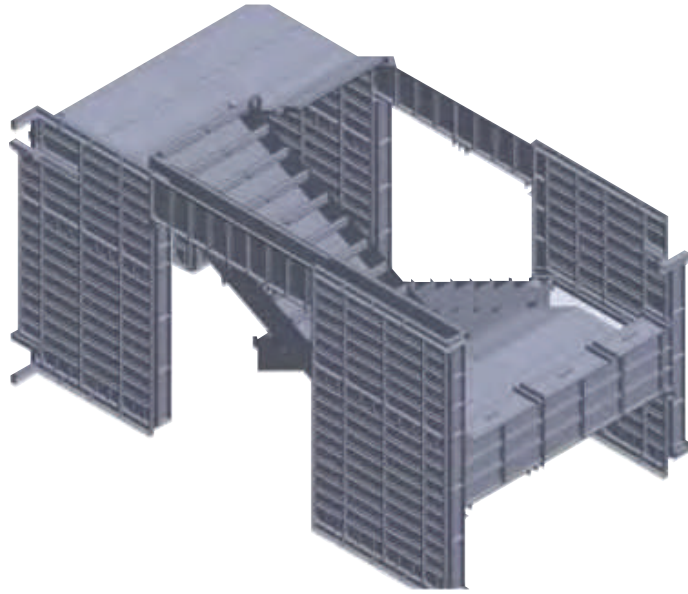

**Completion Of Slab
And Stair Case**

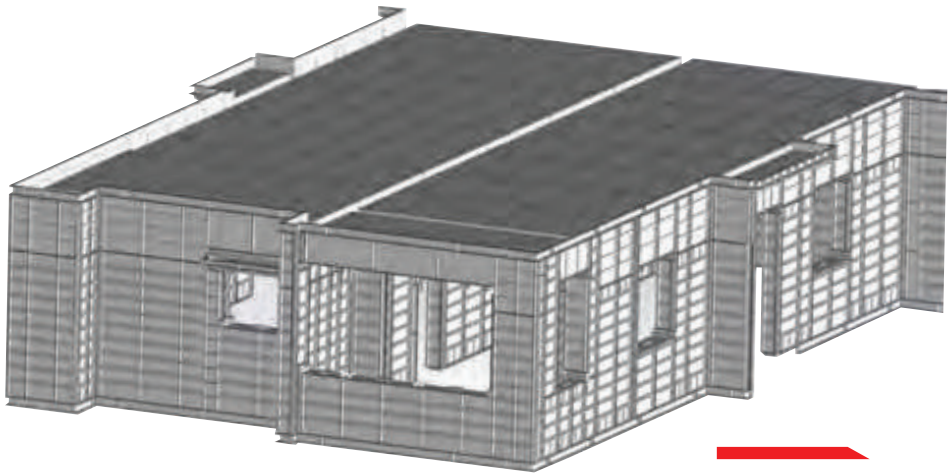

**3d Design Of
Building**

**“ Quality Cost
Time Quantity ”**

Aluminium Formwork Components



Wall panel

Size: 2050x 600 apprx.
Weight (kg):23.97



Slab panel

Size 1200 x600 apprx.
Weight (kg):12.82 the slab
Panel will be used to support
The concrete weight during
Concrete pouring and Casting

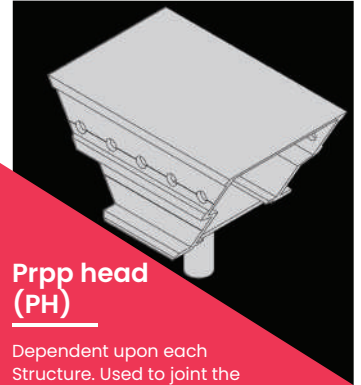

Prop head (PH)

Dependent upon each
Structure. Used to joint the
Beams together (middle beam
And/ or end beam) the pipe
Support will be placed
Under the prop Head



Slab corner

Dependent upon each
Structure. Connection between
Wall panel and slab panel.



Slab inner corner

Dependent upon each
structure Connection between
wall panel And slab
panel (inside)

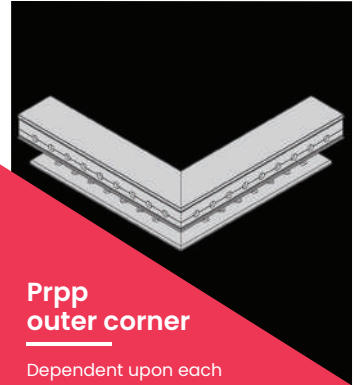

Prop outer corner

Dependent upon each
Structure. Connection between
Wall panel and slab
Panel (outside)



Beam bottom panel

Dependent upon each
Structure. Connection between
Wall panel and slab panel.

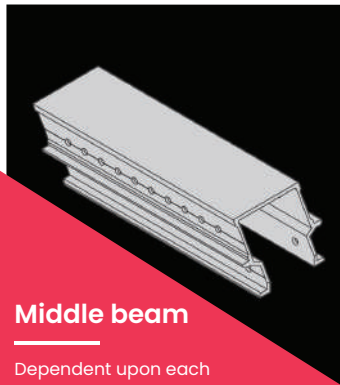

Middle beam

Dependent upon each
Structure. Used to joint the
Prop heads, the middle
Beam supports
The slab panels



End beam (EB)

Dependent upon each
Structure. Used to joint the
Prop head and slab corner
The end beam supports
The slab panels

Bringing Innovations To The Construction Community

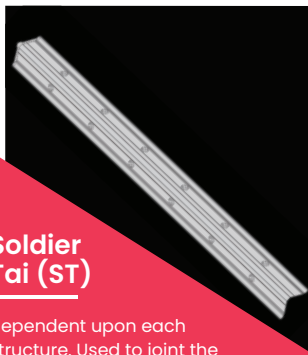

Soldier Tai (ST)

dependent upon each structure. Used to joint the prop head with the beams (middle beam and/or beam)

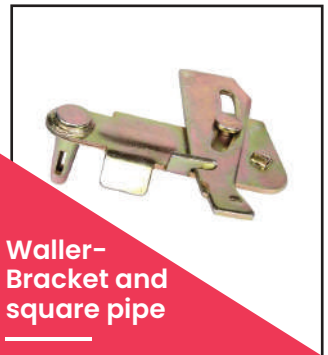

Waller-Bracket and square pipe

Bracket and square pipe—dependent upon each structure. The Waller-Bracket.



Long pin

dependent upon each structure. The long pin and wedge pin will be used to fix the joint pin with the prop head.

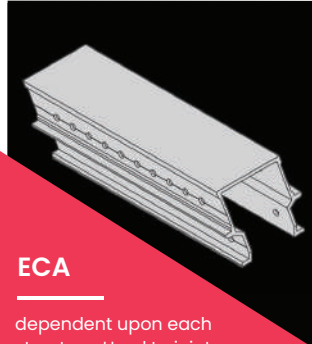

ECA

dependent upon each structure. Used to joint panels together around the corners



PVC sleeve

dependent upon each structure. Made of PVC material, the PVC sleeve will be installed.



Pipe support

dependent upon each structure. The pipe support is used to support the weight of the slab during concrete pouring and casting.

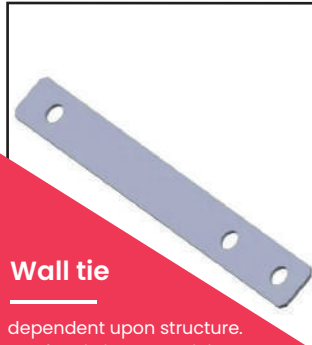

Wall tie

dependent upon structure. The flat tie is used to joint the wall panel to the opposite side's wall panel.

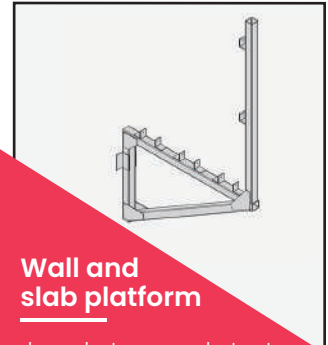

Wall and slab platform

dependent upon each structure. As a substitute of a scaffolding system, this wall platform, slab platform.

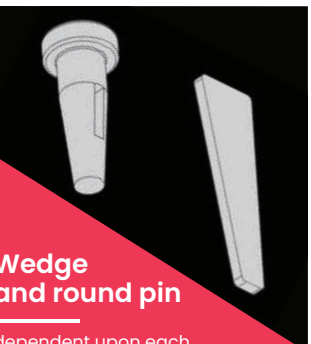

Wedge and round pin

dependent upon each structure. The round pin and wedge pin will be used to joint the wall.

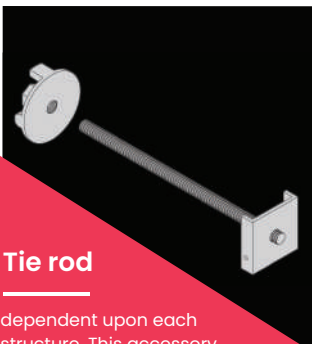

Tie rod

dependent upon each structure. This accessory will be used as an embedded anchor in order to fix the bracket.



Bolt, nut and washer

dependent upon each structure. This set of accessories will be used as an embedded anchor in order to fix panels.

Advantages

- ▶ No plastering required
- ▶ Savings on overhead expenses due to speedy construction (7 days per floor)
- ▶ Monolithic crack free structures
- ▶ Doesn't require Timber or plywood for construction activities
- ▶ Casting of walls and slabs possible simultaneously
- ▶ Doesn't require skilled labour
- ▶ Floor slab forms removed without moving props
- ▶ Earthquake resistance of resulting structures increases manifold
- ▶ The formwork is specifications to allow rapid construction on all types of architectural layouts.
- ▶ Total system forms the complete concrete structure
- ▶ Custom designed to suit project requirements
- ▶ Unsurpassed construction speed
- ▶ High quality finish
- ▶ Eliminates plastering, saves almost 50% construction time
- ▶ The system becomes cost effective were there is considerable repetition of floor layouts on a project such as in the case of low cost mass housing
- ▶ Panels can be used up to 200 times
- ▶ Erected using unskilled labour
- ▶ Requires no cranes or heavy lifting equipment
- ▶ Suitable for low as well as high rise buildings

Pin And Wedge System

the panels are held in position by a simple pin and wedge system that passes through holes in the outside rib of each panel. The panels fit precisely, simply and securely. They required no bracing full stop buildings can be constructed quickly and easily by unskilled labour with a hammer being the only tool required. Once the penis have been numbered, measuring is not necessary full stop as the erection process is manual, tower cranes are freed up and can concentrate on other handling operations. The result is a typical 4 to 5 day cycle for floor to floor construction.

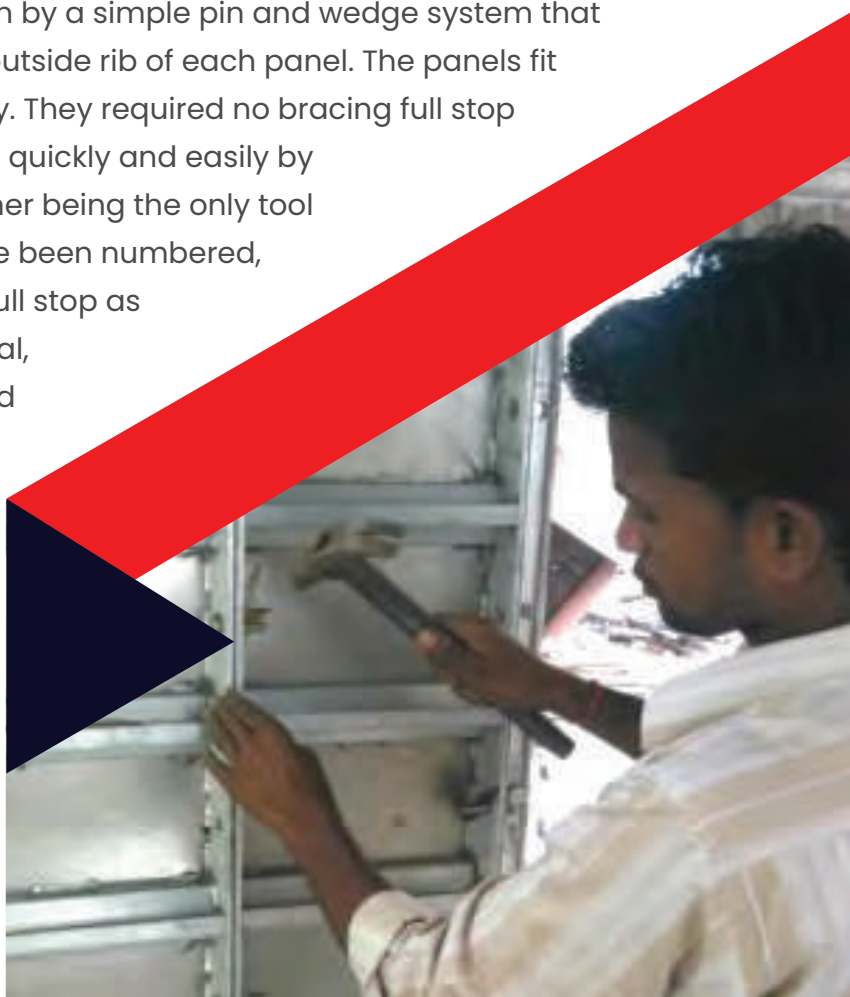

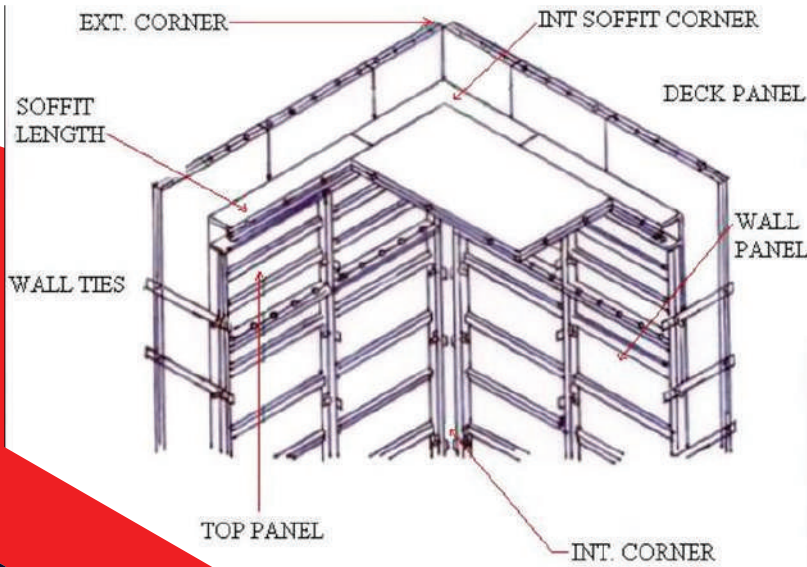

Speed And Quality

The insitu construction of all walls and partitions reduces the requirement for follow on wet trades. The concrete surface finish produced with the aluminium forms allows achievement of a high quality wall finish without the need for extensive plastering. Doors and windows are formed in position, with this high degree of precision items such as door and window frames can be directly installed on site with minimal resizing required.

High quality aluminium formwork panels ensure consistency of dimensions full stop on the removal of the formwork mould, a high quality concrete finish is produced to accurate tolerances and verticality. The high tolerance of the finish means that no further plastering is required. Typically a 3 mm to 4 mm skin coat is applied internally prior to finishing and a 6 mm build up coat prior to laying tiles.

Quick Strip Prop Head

One of the principal technical features which enables this speed to be attained using a single set of formwork panels is the unique V shaped prop head which allows the 'quick strip' to take place whilst leaving the propping and disturbed. The deck panels can therefore be reused immediately.



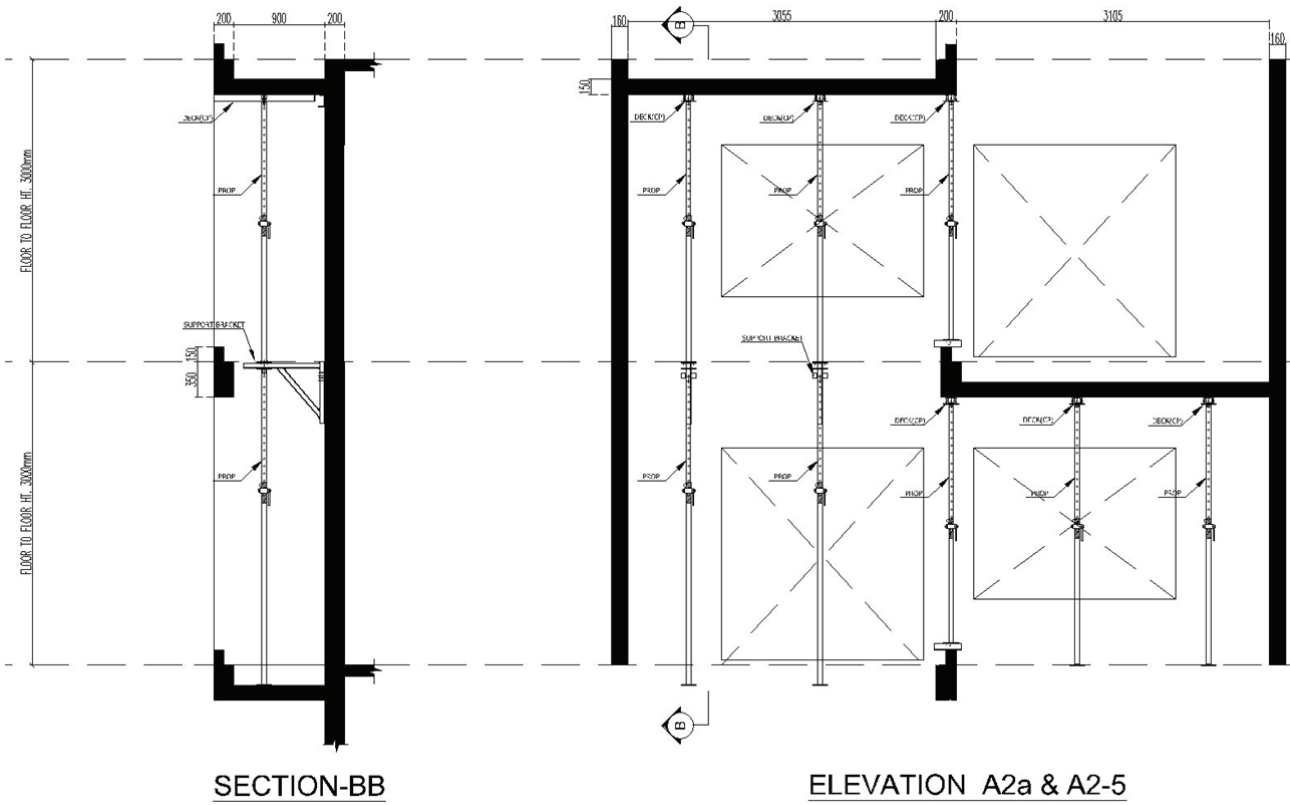

SECTION-BB

ELEVATION A2a & A2-5

For Double Height Slab

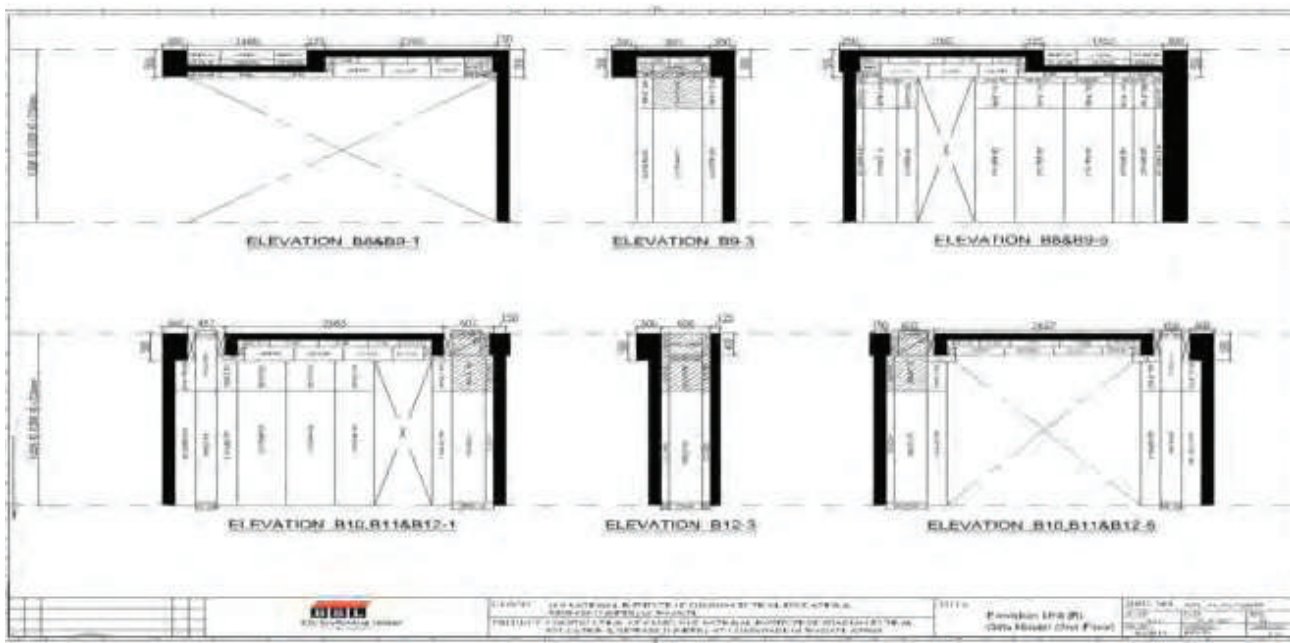

For Double Height Slab



**ALUMINIUM
FORMWORK
FOR A BETTER
WORLD**

Address Office

GRS Formwork Pvt. Ltd.
Emami City Business Tower
2, Jessore Road, Kolkata - 700028

Factory

LP Industrial Area, Jagdishpur
Road, Near Maa Tara Weight
Bridge, Howrah



Contact Us

+91 90077 50027

grsformwork@gmail.com

www.grsaluminiumformwork.com

